

Scooptram EST3.5

Underground electric loader with 6 tonne load capacity



Reliable loader for small to medium sized mines

The Scooptram EST3.5 is designed for small to medium sized operation. It has been proven in mines around world where local conditions is for electric loaders or those that insufficient ventilation for diesel loaders.

+ Main benefits

High safety Scooptram EST3.5 offers high safety, such as ISO ROPS/FOPS approved operator's canopy, boom up lock device, wheel chocks, audio-visual reverse alarm, spring applied hydraulic released brake system, ground fault /ground check systems and 3-point contact and anti-skid protection.

Zero emission Electric driven entirely without diesel emissions makes Scooptram EST3.5 minimizes the need for ventilation.

Serviceability thanks to an easily serviced machine – easy access to all daily service points, saving time, reducing cost of operation and improving the service life.

Boom up lock device



New strengthened cable with automatic tensioning cable reel is more wearable and extend service life.



Ground fault and ground check systems are installed to ensure personnel safety.



Automatic lubrication increases the MTBM (mean time between maintenance).



ISO ROPS/FOPS approved operator's canopy

Conventional and proven components are well protected within the frame

Random wrap cable reel with automatic tensioning

Audio-visual reverse alarm

SAHR bakes - safest brake system in the mining industry

Ergonomic operator seat with seat belt

High ground clearance protects the machine from damage

Various voltages for individual design

Scooptram EST3.5 has a variety of voltages and frequencies for your selection, and Epiroc also provides various cables to meet your needs of power supply system in different applications.

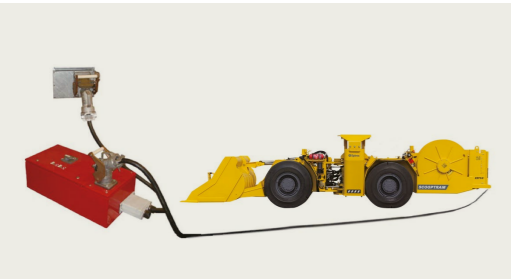

+ Safety

The Scooptram EST3.5 is designed for high level of safety, such as the ground fault and ground check systems installed to protect personal safety in the mine.



+ Comfort

Side seated operator position for efficient bi-directional operation ensures wide visibility. Ergonomic operator seat with seat belt provides comfort during a full work shift.



+ Convenience

ABB electric motor with overload protection and onboard start applies to various voltages and electrical frequencies; Random wrap cable reel with automatic tensioning is also available for various cable and matches to the mine electric systems.



A comprehensive service offering

Even the best equipment needs to be serviced regularly to make sure it sustains peak performance. An Epiroc service solution offers peace of mind, maximizing availability and performance throughout the lifetime of your equipment. We focus on safety, productivity and reliability.

By combining genuine parts and an Epiroc service from our certified technicians, we safeguard your productivity – wherever you are.

Technical Specifications

● - Standard ○ - Option

Specifications

Capacities	
Tamming capacity*	6 000 kg
Breakout force, hydraulic	9 960 kg
Breakout force, mechanical	8 180 kg
*Tramming capacity with EOD bucket 5 100 kg.	
Motion times	
Boom raising	6.0 sec
Boom lowering	5.0 sec
Dumping	3.6 sec
Weights (Standard empty vehicle)	
Approximate weight	17 900 kg
Axle load, front end	7 400 kg
Axle load, rear end	10 500 kg

Engine

	Standard
ABB Electric Motor	3 phase, 50 Hz and 60 Hz
Power rating at 2 300 rpm	74.6 kW / 100 hp
Motor overload protection	
On board start system	
Ground fault and ground check system	

Transmission

Full power shift, 3 speeds forward and reverse, intergral single stage converter	●
Brand/model: Dana, R32 000 Series	●

Axles

Brand/model: Rock Tough 406	●
Degree of rear axle oscillation: 14' (7" on each side)	●
Differentials: Front, No spin	●
Differentials: Rear, Standard	●

Brakes

Fully enclosed, multiple wet discs at each wheel end	●
Service/ parking/emergency brakes: SAHR	●
Brake cooling	○
Brake release retriever tow hook	○

Tyers

Tubeless tyres design for underground mine service*	●
Inverted rims - Tyre lock on inside	○
Tyre size front and rear: 175 R25 (slicks)	○
Tyre size front and rear: 175 R25 (treaded)	○
* As applications and conditions vary, Epiroc recommends that the user consults with tyre suppliers to obtain the optimum tyre selection.	

Operator's compartment

Canopy (ISO ROPS and FOPS approved)	●
Side seated operator for bi-directional operation and maximum visibility	●
Ergonomic operator seat with seat belt	●

Hydraulic system

Heavy duty gear type pumps	●
System pressure: 13.8 MPa	●
Hydraulic tank capacity 273 litres	●
Filtration, suction line: 25 µm	●
Manual hydraulic tank fill pump	○
Steer cylinder: chrome plated stem, 2 × 89 mm diameter	
Hoist cylinder: chrome plated stems, 2 × 152 mm diameter	
Dump cylinder: chrome plated stems, 1 × 152 mm diameter	

Control system

Monostick steering control	●
Single lever dump and hoist control	●
Bucket float control	○
Blockout 3rd gear	○

Electrical system

System voltage: start & accessories, 24 V	●
Low hydraulic oil level warning	○
Audio-visual reverse alarm	●
Isolating switch lockout	●
Electrical hydraulic tank fill pump	○
Driving lights Halogen: 8 × 70 W	●
Shielded trailing cable	○
Driving lights LED: 8 × 1 800 lumen, 22 W	○

Cable reel

Random wrap with automatic tensioning	●
Standard reel diameter: 1 371 mm	●
Automatic brake application at cable end position	●

Main frame

KA requirement	○
Center hinge and boom up lock device	●
EOD bucket	○
Wheel chocks and chocks brackets	○
Knockdown construction	○
Central manual lubrication	●
Automatic lubrication system with timer	○
Handheld fire extinguisher	○
Ansul manually activated fire suppression system with engine shut down	○
Tool box	○

Parts and services

Face mechanics tool set	○
Preventive maintenance kits	○
Repair and rebuild kits	○
Upgrade kits	○
Operator training	○

Documentation

Digital operator / spare parts manual	●
Operator manual - paper	○
Spare parts manual - paper	○

Technical Specifications

Grade performance

Standard configuration, empty bucket														
%	Grade	0.0	2.0	4.0	6.0	8.3	10.0	12.5	14.3	16.0	18.0	20.0	25.0	30.0
Ratio	Grade					1:12	1:10	1:8	1:7				1:5	1:4
km/h	1st gear	2.8	2.7	2.7	2.6	2.5	2.5	2.4	2.4	2.3	2.2	2.1	1.8	1.4
	2nd gear	5.6	5.3	5.1	4.8	4.3	3.8	3.1	2.6	2.2	1.6	0.9		
	3rd gear	9.1	8.4	7.0	5.2									

3% rolling resistance assumed. Actual performance may vary depending on the application.

Grade performance

Standard configuration, loaded bucket														
%	Grade	0.0	2.0	4.0	6.0	8.3	10.0	12.5	14.3	16.0	18.0	20.0	25.0	30.0
Ratio	Grade					1:12	1:10	1:8	1:7				1:5	1:4
km/h	1st gear	2.8	2.7	2.6	2.5	2.4	2.4	2.2	2.1	1.9	1.7	1.5	1.1	0.7
	2nd gear	5.4	5.1	4.7	4.0	3.1	2.5							
	3rd gear	8.8	7.2	4.9										

3% rolling resistance assumed. Actual performance may vary depending on the application.

Cable Specification

Cable and reel		Maximum cable length (m) based on voltage							
Cable size/dia. mm	Reel dia. mm(ft)	380V, 50Hz	415V, 50Hz	440V, 50Hz	460V, 60Hz	550V, 50Hz	575V, 60Hz	660V, 50Hz	1 000, 50Hz
35 mm ² /33	1 291(48)	90	104	110	130	130	130	130	130
	1 371(54)	90	104	110	130	175	175	175	175
	1 524(60)	90	104	110	130	175	200	250	250
50 mm ² /36	1 291(48)	100	100	100	100	100	100	100	100
	1 371(54)	100	100	130	130	130	130	130	130
	1 524(60)	100	100	130	150	175	175	175	175
70 mm ² /44.5	1 291(48)	76	76	76	76	76	76	76	76
	1 371(54)	107	107	107	107	107	107	107	107
	1 524(60)	107	122	122	122	122	122	122	122

Measurements

Dimensions

- Turning angle +/-42.5°
- All dimensions shown are based on standard vehicle configuration with 27 mm tyre deflection, unloaded
- All dimensions are shown in millimetres

Technical specificatio

Turning radius

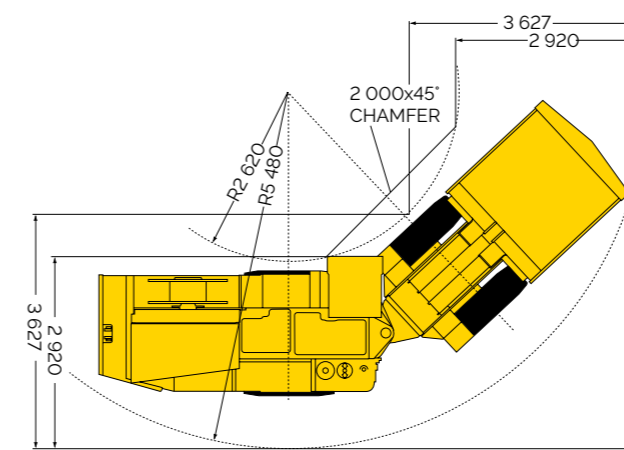

Rear view

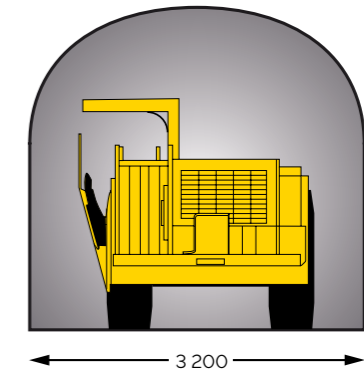

Side view

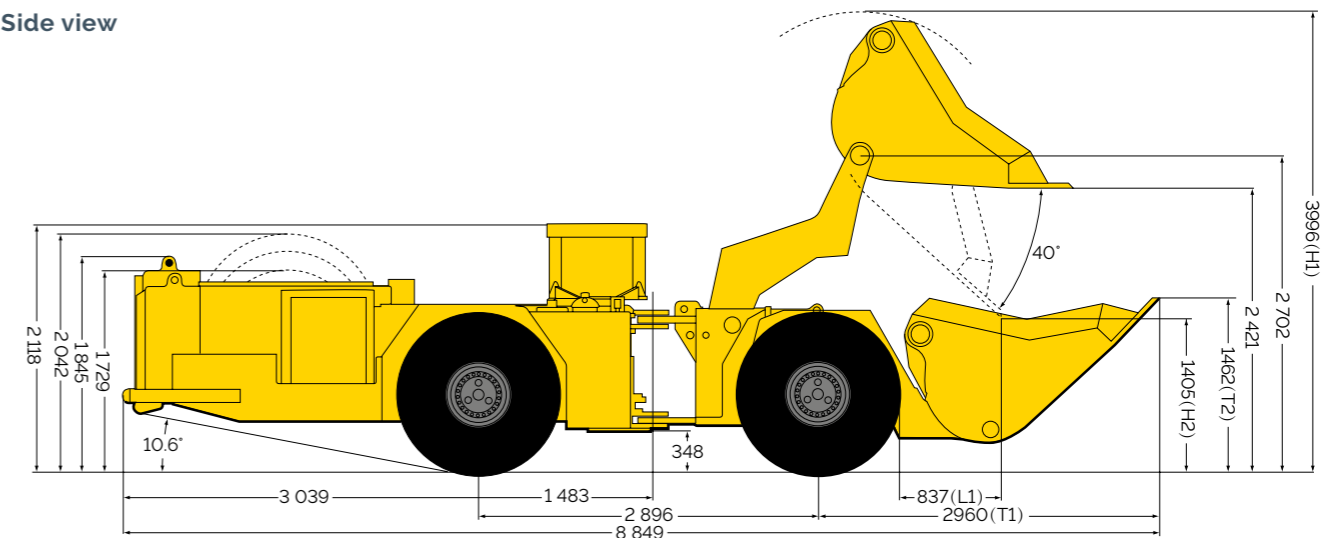

Top view

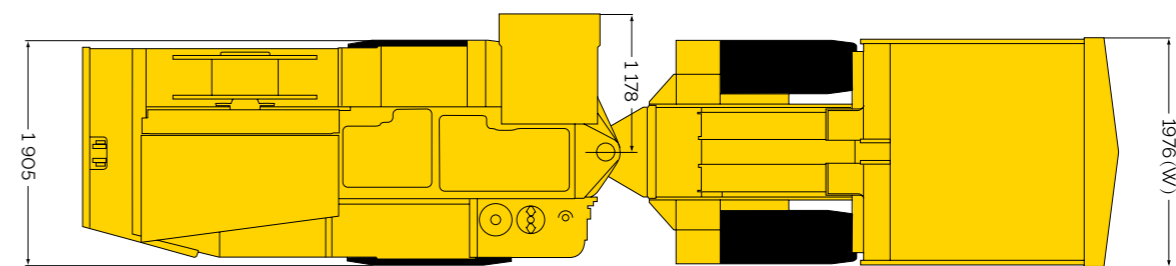

Bucket Data

	STANDARD				EOD				
				STD					
Volume, nominal heaped (m ³)		2.3	2.7	3.1	1.8	2.0	2.7	3.1	3.4
Maximum material density (t/m ³)		2.6	2.2	2.0	2.8	2.6	2.0	1.8	1.4
Width, bucket (mm)	W	1976	1976	1976	1976	1976	1976	2171	2424
Tramming position: Axle centerline to bucket lip (mm)	T1	2629	2804	2960	2869	2871	2969	2938	2938
Tramming position: Ground to bucket lip (mm)	T2	1345	1375	1462	1471	1469	1555	1573	1574
Reach dimension (mm)	L1	591	680	837	980	975	1085	1070	1069
Raised position: Back height, max. (mm)	H1	3818	3878	3996	3949	3945	4048	4040	4039
Raised position: Bucket tip, height (mm)	H2	1589	1502	1405	1631	1624	1552	1556	1553

* EOD bucket, for sizing of buckets and boxes, please consult your local Customer Center

United in performance. Inspired by innovation.

Performance unites us, innovation inspires us, and commitment drives us to keep moving forward. Count on Epiroc to deliver the solutions you need to succeed today and the technology to lead tomorrow.
epiroc.com

