

SmartROC T30 R

Tophammer surface drill rig for quarrying and construction

Hole diameter: 45–89 mm (1.8"–3.5")



A smart rig for smarter operators

A powerful and versatile partner which is ready to help you take on the toughest jobs.

You work alone in the background, — building the infrastructure which keeps society running smoothly. You are first on-site and the last to go home. We know how it is. Epiroc has designed this rig to work as hard as you do.

The SmartROC T30 R will follow you into the roughest terrain, or the most remote construction site. It is ready to be your new, powerful best friend and help you deliver results, shift-after-shift.



Discover more about
the SmartROC T30 R.

Your new best friend

The SmartROC T30 R features a smart control system (RCS) which presents you with all the information you need to get the job done. It features an intuitive 10" touchscreen display so you can keep track of drilling operations and rig settings. The control system also automatically optimizes power output which reduces fuel consumption. This helps to keep costs low and reduce your environmental impact. A SmartROC rig also logs valuable data during drilling which can be downloaded and analyzed to further improve operations.

The Smart RCS also opens the door to automation plus many valuable options. This rig includes a rod handling system which increases consistency, reduces wear on consumables and boosts productivity.

The Hole Navigation System (HNS) option allows you to upload a pre-prepared drill plan. Each hole can then be drilled with extreme accuracy without the need for manual marking. This saves time and cuts down on the amount of explosives used.

Epiroc is constantly pushing and developing updates, new features and options for SmartROC rigs. These can be installed in your SmartROC T30 R in the future thanks to the Smart control system. This helps to safeguard your investment, further boost productivity and keep your most trusted workmate in top condition.

⊕ Main benefits

Smart. A SmartROC rig features a high level of automation along with impressive, production-boosting options such as the Hole Navigation System. Easily-installed updates safeguard your investment and keep your rig up-to-date.

Exceptional coverage. A 45°/45° swing radius coupled with 5.7 meter boom system equipped with a hydraulic 360° feed swing helps you spend more time drilling and less time setting up.

Great terrainability. A low center of gravity, wide track spacing and highly maneuverable boom enable the rig to follow you into the roughest terrain.



Compact dimensions, versatile feed with 360° swing and great lighting options means the SmartROC T30 R is at home underground and on the surface. Wherever you need to work, this rig will be right there by your side.



The SmartROC T30 R is easy and cost effective to transport due to its well-balanced, compact, thought-out design. It's also simple to service thanks to large access hatches. Service points are grouped together to make life easier.



The SmartROC T30 R packs a powerful punch for a rig in this class. A COP SC19 HF rock drill with 160 or 250 cc and a compressor delivering 80 l/sec combined with the Volvo Penta diesel engine (105 kW/143 hp) ensures that together, you can handle the toughest rock conditions.

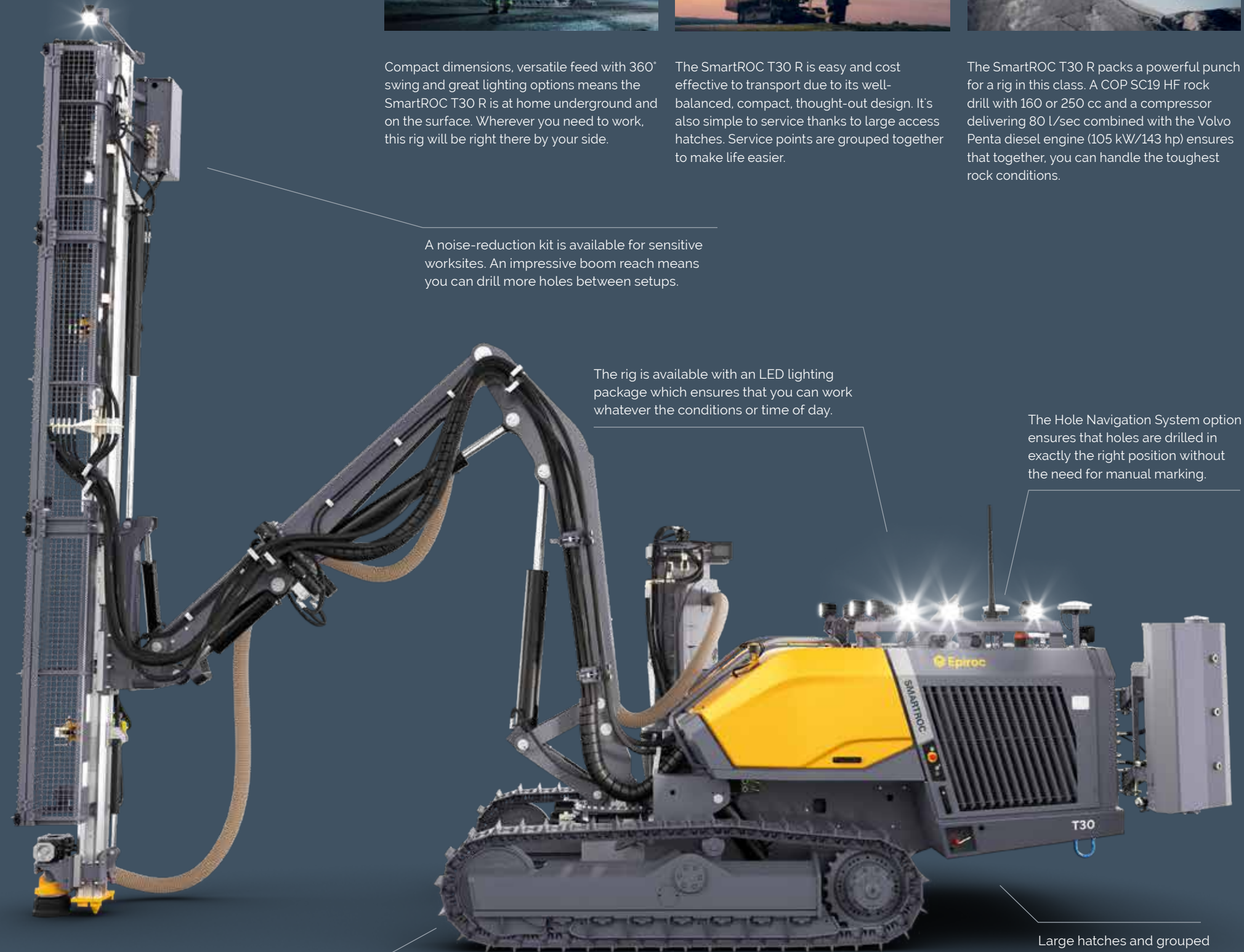

A noise-reduction kit is available for sensitive worksites. An impressive boom reach means you can drill more holes between setups.

The rig is available with an LED lighting package which ensures that you can work whatever the conditions or time of day.

The Hole Navigation System option ensures that holes are drilled in exactly the right position without the need for manual marking.

Wide track placement, good ground clearance combined with excellent balance ensure that this rig has class-leading reach and coverage without compromising on safety or stability.

Large hatches and grouped service points make for quick and easy servicing.

Goodbye dust and noise. Hello, more meters per shift



A remote worksite with tough rock conditions? No problem. You can count on your SmartROC T30 R to get the job done.

Not all worksites are the same. Rock conditions and access can vary greatly. In order to get the job done, you need a rig which is both agile and powerful. The SmartROC T30 R is just that machine. It's a no-compromise mix of balance, power and agility which delivers top-performance, even in the toughest conditions.

Some locations include strict regulations regarding noise pollution. The SmartROC T30 R is available with a noise-reduction option. This allows the rig to operate problem-free in these sound-sensitive areas.

Designed for you — and all kinds of rock

We know that your job is anything but monotonous. Each day is different, and presents you with unique problems and challenges. The SmartROC T30 R has been designed with this in mind. Impressive boom coverage, a smart control system and unrivaled adaptability all add up to make sure you get the job done safely, efficiently and on-time. It is also extremely powerful for a machine with such a small footprint.



+ Smart control system

The Smart control system enables you to tune the drilling process so that you can get the rock drill to perform to perfection. Its intuitive interface is easy to understand so you can get up and running in no time at all. The control system also makes it simple and quick to install new updates in the future. Engine RPM and compressor load are automatically adjusted by the system to ensure that maximum efficiency is achieved throughout the drilling process.



+ Reduced environmental impact

At Epiroc, our goal is to help your operation be as sustainable as possible. The rig is fitted with a Volvo Penta diesel engine with a smart control system which ensures that fuel is not used unnecessarily. A noise reduction option is also available to ensure that sound pollution is kept to a minimum in sensitive areas.



+ Tough terrain? No problem

The SmartROC T30 R has a low center of gravity to help it stay balanced on rough ground. We've also increased the space between the crawler tracks which helps to improve stability. The boom is also extremely manoeuvrable which makes it a great counter-weight when tramping over uneven ground. A lab-type drill support leg ensures a stable set-up whilst a winch allows you to anchor the machine securely to get up and down steep inclines.



A comprehensive service offering

Even the best equipment needs to be serviced regularly to make sure it sustains peak performance. An Epiroc service solution offers peace of mind, maximizing availability and performance throughout the lifetime of your equipment. We focus on safety, productivity and reliability.

By combining genuine parts and an Epiroc service from our certified technicians, we safeguard your productivity – wherever you are.

Main Components

- Crawler type two speed undercarriage with track oscillation system
- Powerful COP SC19 HF Rock drill
- Volvo Penta diesel engine
- Atlas Copco screw type compressor
- Versatile folding boom system
- Labb-type drill support leg
- Rock drill lubrication-oil collection-system (ECL)
- 5.7 meter (18.7 ft) feed
- Smart control system with 10" touchscreen
- Rod Handling Systems, RHS
- High capacity Dust Collection System, DCT
- 360° feed swing
- Radio Remote Control system with integrated display

Recommended hole range

Feed type	Metric	US	Thread	Rod Handling System (RHS)
				3+1 rods
5.7 meter (14 ft) feed	Ø 48-89 mm	Ø 1.5"-3.5"	R32, TC35, T35, T38, T45	14.8 m'

Engine (HVO 100-compliant)

Volvo Penta TAD 580 VE turbo-charged diesel engine, Tier 4 Final/Stage 5	
Power rating at 1 975 rpm	105 kW/143 hp
Electronic variable engine speed	900 - 1975 rpm
Variable fan control	
Green saver – automatic low engine speed	

Volvo Penta TAD 580 VE turbo charged diesel engine, Tier 3	
Power rating at 1 975 rpm	105 kW/143 hp

Dust collector DCT

	Metric	US
Filter area	7 m ²	75 sq.ft
Suction hose diameter	102 mm	4"
Cleaning air pressure, max	7.5 bar	109 psi
Cleaning air consumption at 7 bar	15 l/pulse	0.53 cu.ft./pulse
Filter cleaning while drilling		
7 pcs of filter elements		

Weight

Standard unit excluding all options and drill steel	Metric	US
Provisional max weight	11 900 kg	26 235 lbs

Feed swing

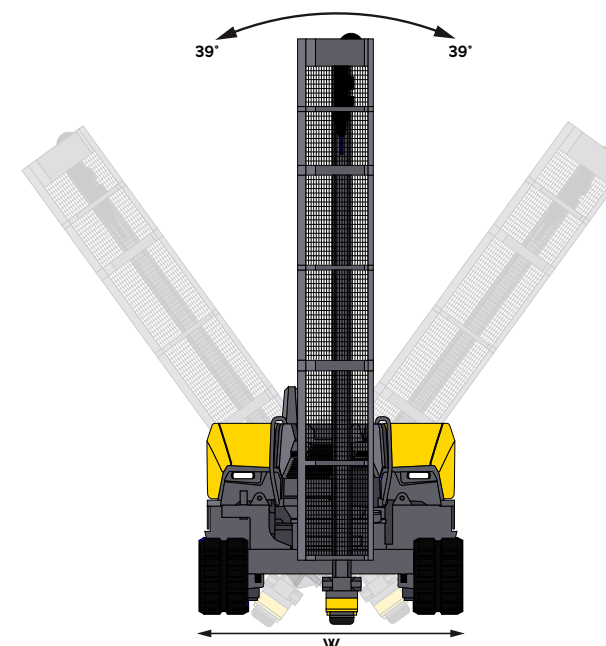

Transport dimensions

Height (H)	2 950 mm (116')
Length (L)	6 600 mm (260')
Width (W)	2 450 mm (96.5')

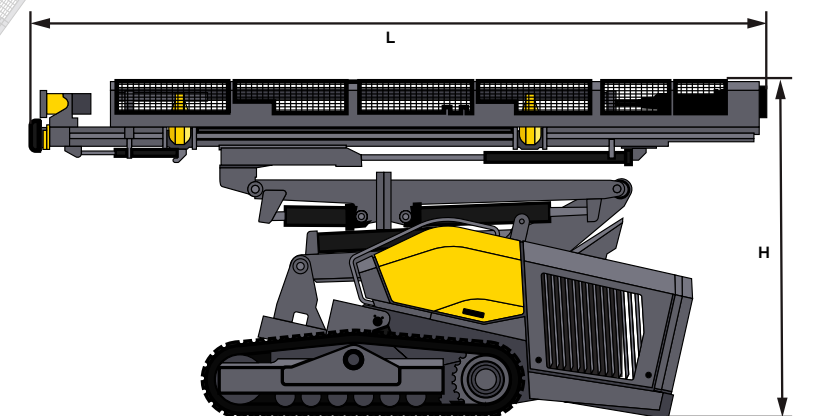

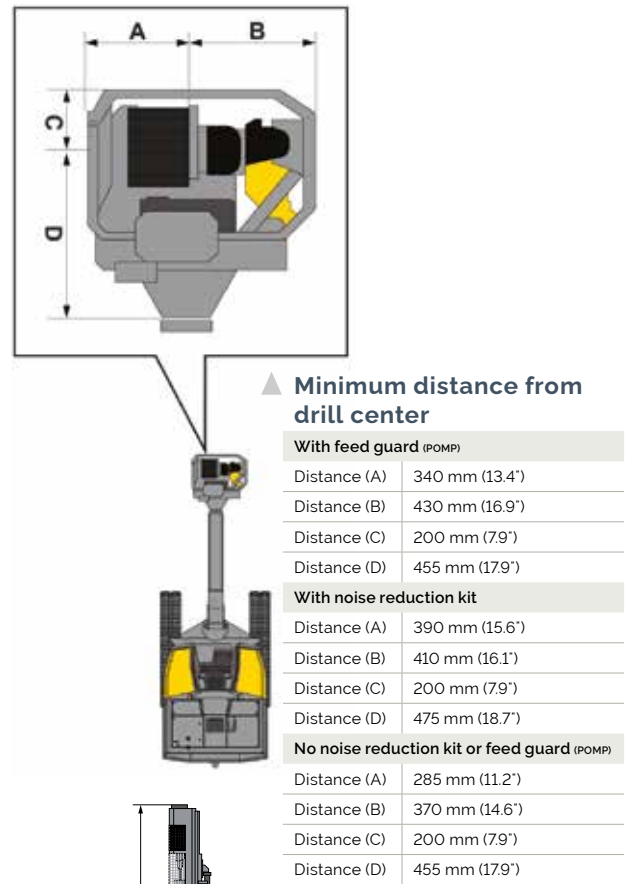
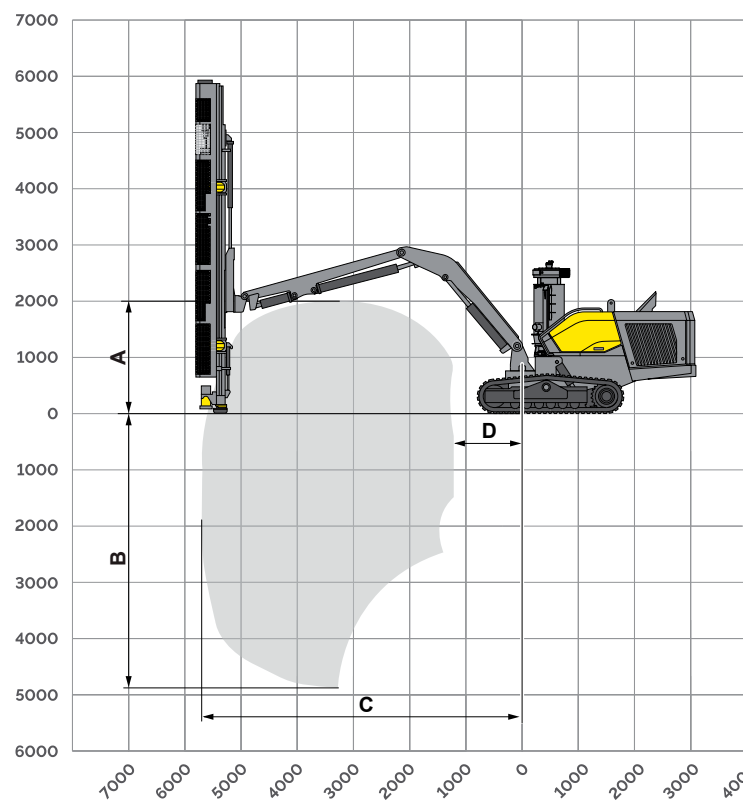
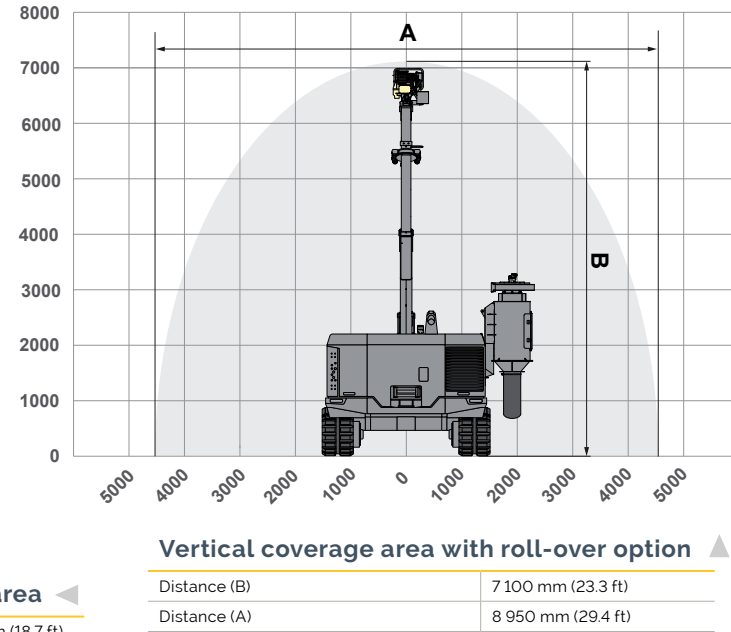
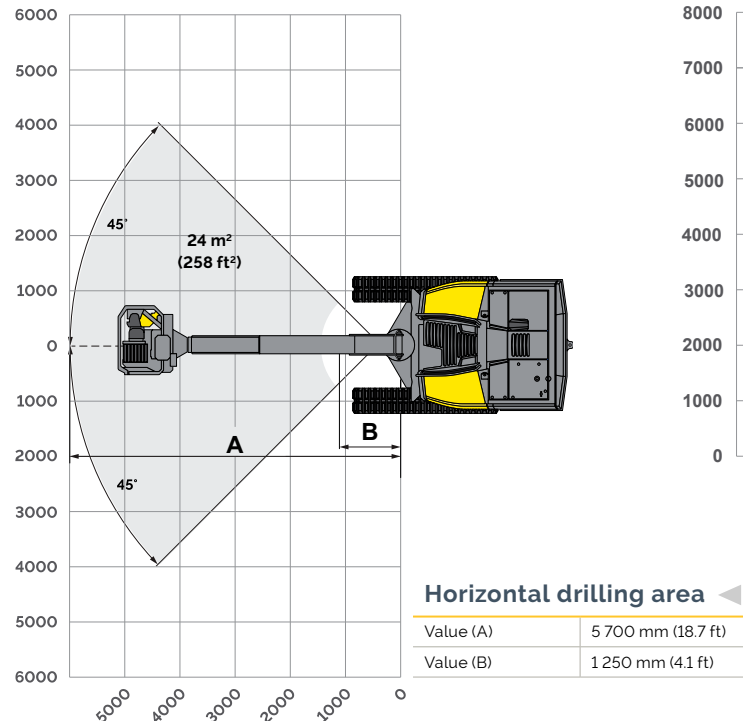

Drilling position dimensions

Height (A)	5 900 mm (19.4 ft)
Height (B)	2 650 mm (8.7 ft)
Length (C)	2 900 mm (9.5 ft)
Length (D)	4 250 mm (13.9 ft)
Length (E) with water mist tank	4 600 mm (15.1 ft)

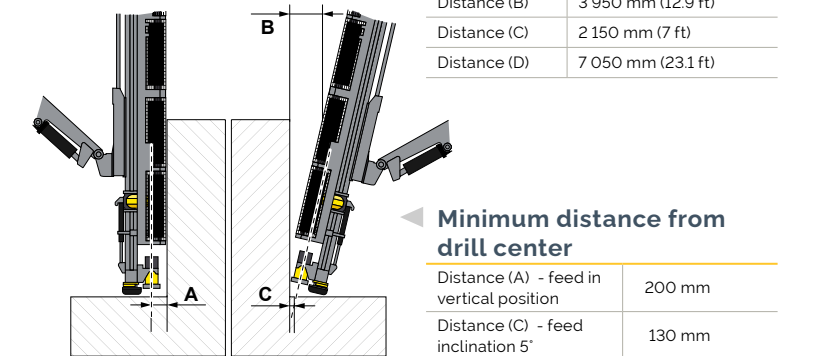
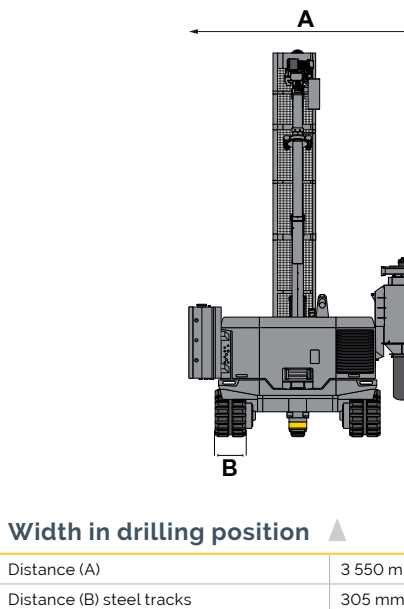
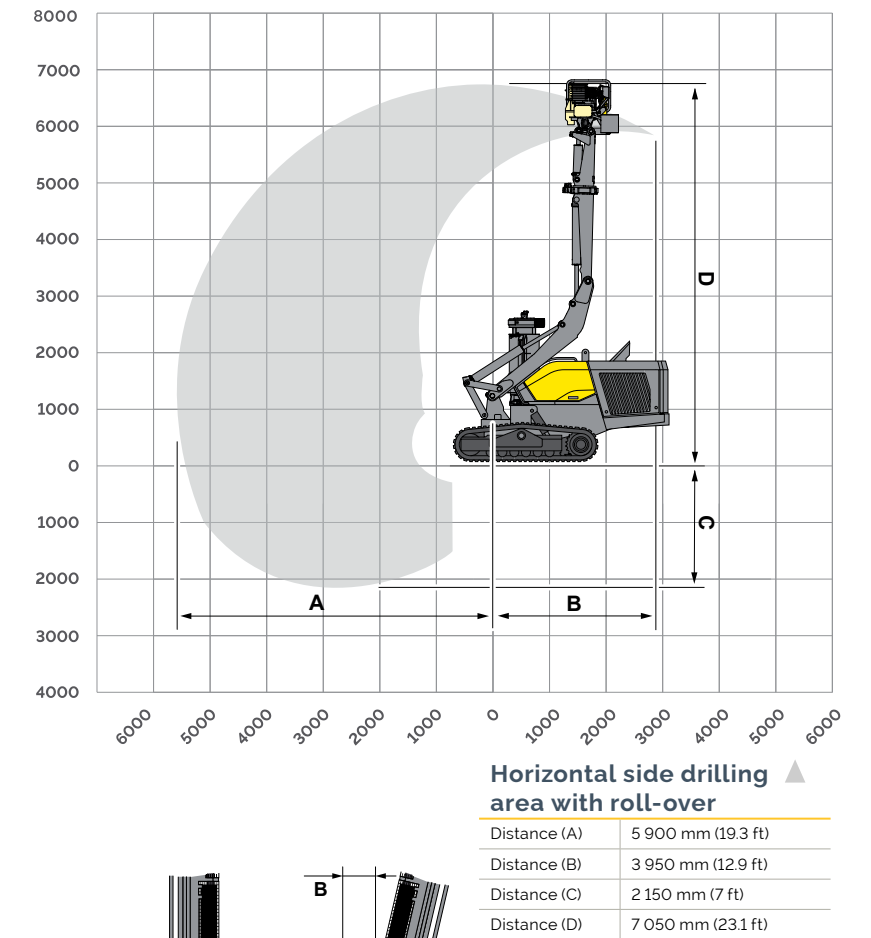
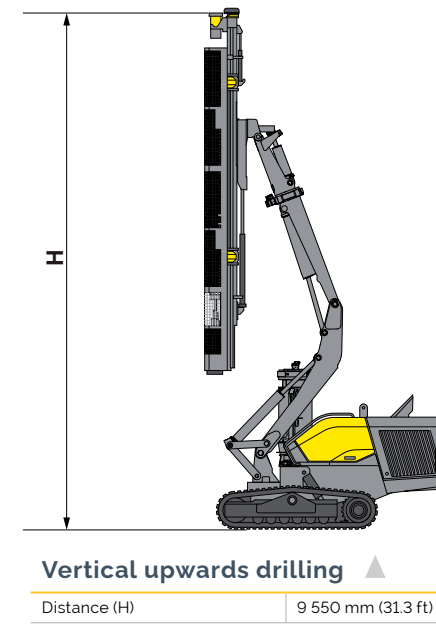
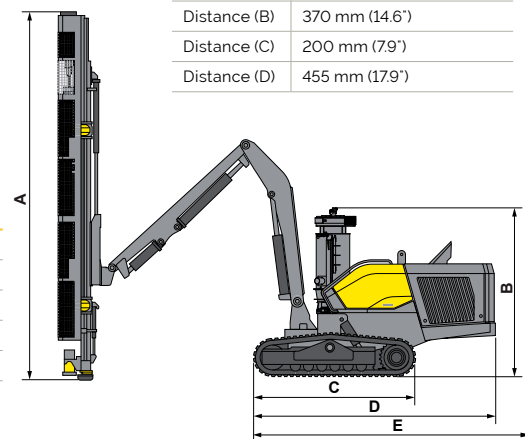

Selection of options

Feed and boom

- Movable suction hood/drill-steel support
- Hydraulic roll-over
- Protection of Moving Parts (PoMP)
- Rubber disc for DCT
- Rubber hood for DCT
- Noise reduction kit
- Thread lubrication system - ECG

Carrier

- Grind Matic RH4 — bit grinder
- Programmable blast horn
- Central Lubrication System (CLS)
- Diesel-driven engine heater
- Electric fuel-filling system
- Hydraulic winch

Hole and inclination systems

- GPS compass aiming unit
- GNSS compasses for aiming, height control and hole logging
- Hole navigation system with remote display

Additional options

- Spare radio transmitter (radio remote control)
- Hydraulic waterpump for waterflushing
- Water mist system with 150 L tank and hydraulic pump
- Water mist system with 50 L tank and hydraulic pump
- Extra lights
- Hydraulic AUX outlet
- Bag handling system for DCT

Additional options - not mounted

- Basic toolkit
- Conversion kit R32
- First 50 hrs service kit for compressor
- Gas charging equipment for rock drill
- Lubrication kit
- Belt for radio remote control (RRC)/OU
- Parts book – hard copy

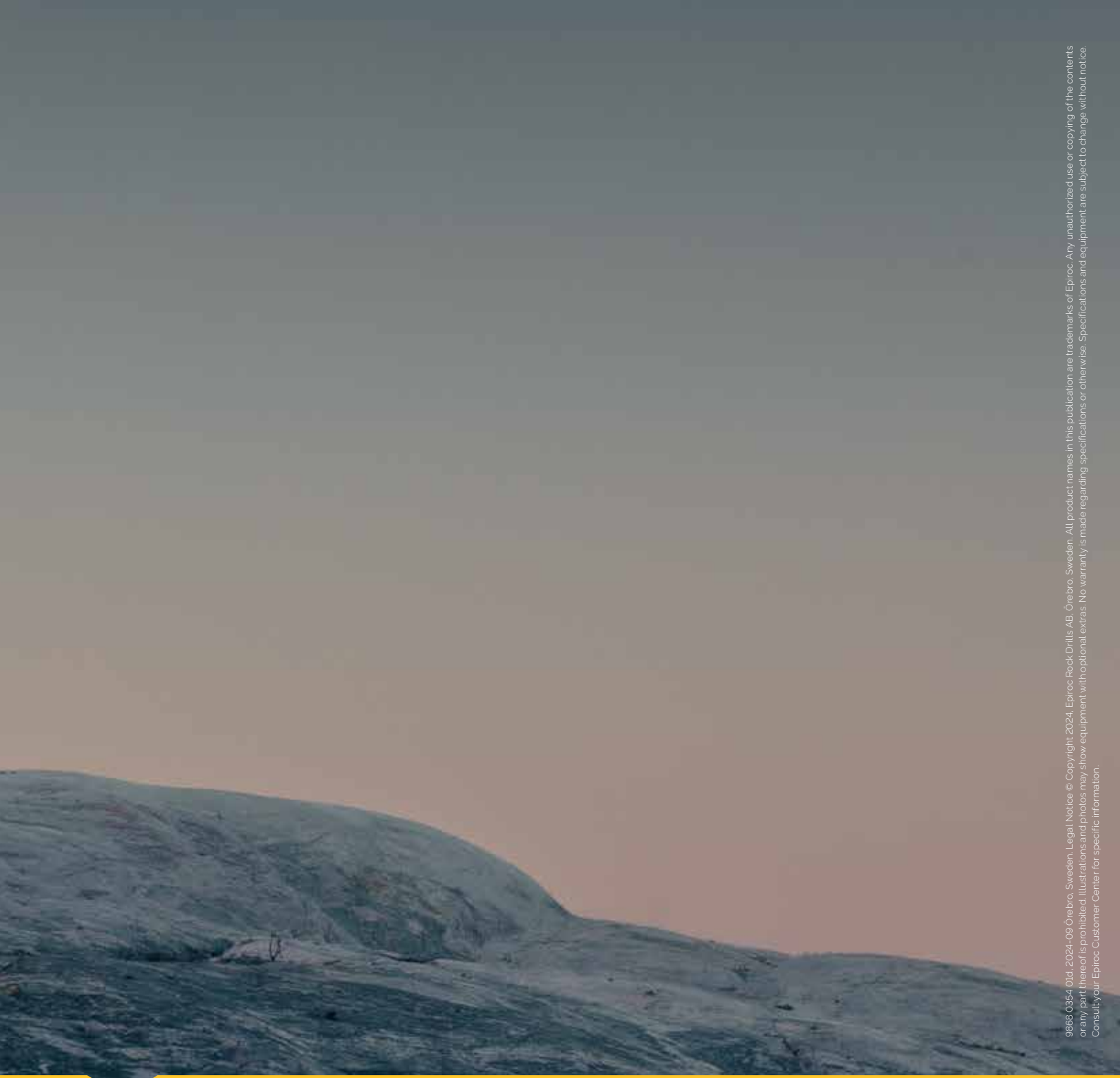

9866 0354 01d, 2024-09 Orebro, Sweden. Legal Notice © Copyright 2024, Epiroc Rock Drills AB, Orebro, Sweden. All product names in this publication are trademarks of Epiroc. Any unauthorized use or copying of the contents or any part thereof is prohibited. Illustrations and photos may show equipment with optional extras. No warranty is made regarding specifications or otherwise. Specifications and equipment are subject to change without notice. Consult your Epiroc Customer Center for specific information.

United in performance. Inspired by innovation.

Performance unites us, innovation inspires us, and commitment drives us to keep moving forward. Count on Epiroc to deliver the solutions you need to succeed today and the technology to lead tomorrow.
epiroc.com

